

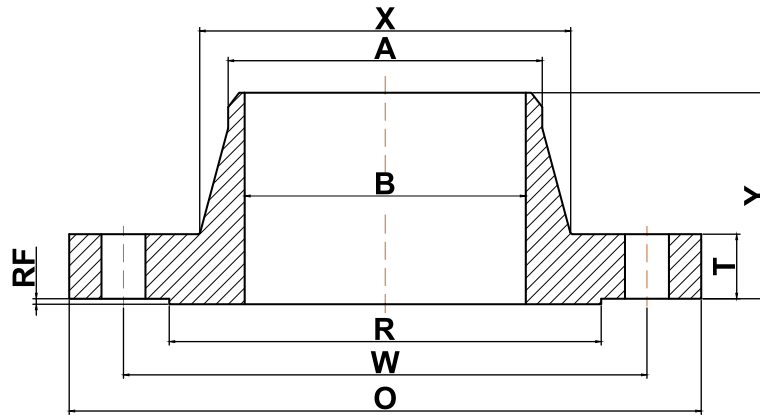

ANSI b16.5

▶ Class 600 Welding Neck Flanges



Nominal Pipe Size	Outside Diameter (O)	Bolt Circle (W)	Raised Face Diameter (R)	Number of Holes	Diameter of Holes	Bore (B)	Point of Weld (A)	Hub Diameter (X)	Thickness (T)	Length Thru Hub (Y)	Approximate Weight (lbs)
1/2	3.75	2.62	1.38	4	0.63	Specified by purchaser	0.84	1.50	0.56	2.06	2
3/4	4.62	3.25	1.69	4	0.75	Specified by purchaser	1.05	1.88	0.62	2.25	4
1	4.88	3.50	2.00	4	0.75	Specified by purchaser	1.32	2.12	0.69	2.44	4
1 1/4	5.25	3.88	2.50	4	0.75	Specified by purchaser	1.66	2.50	0.81	2.62	6
1 1/2	6.12	4.50	2.88	4	0.88	Specified by purchaser	1.90	2.75	0.88	2.75	8
2	6.50	5.00	3.62	8	0.75	Specified by purchaser	2.38	3.31	1.00	2.88	12
2 1/2	7.50	5.88	4.12	8	0.88	Specified by purchaser	2.88	3.94	1.12	3.12	18
3	8.25	6.62	5.00	8	0.88	Specified by purchaser	3.50	4.62	1.25	3.25	23
3 1/2	9.00	7.25	5.50	8	1.00	Specified by purchaser	4.00	5.25	1.38	3.38	26
4	10.75	8.50	6.19	8	1.00	Specified by purchaser	4.50	6.00	1.50	4.00	42
5	13.00	10.50	7.31	8	1.13	Specified by purchaser	5.56	7.44	1.75	4.50	68
6	14.00	11.50	8.50	12	1.13	Specified by purchaser	6.63	8.75	1.88	4.62	81
8	16.50	13.75	10.62	12	1.25	Specified by purchaser	8.63	10.75	2.19	5.25	120
10	20.00	17.00	12.75	16	1.38	Specified by purchaser	10.75	13.50	2.50	6.00	190
12	22.00	19.25	15.00	20	1.38	Specified by purchaser	12.75	15.75	2.62	6.12	225
14	23.75	20.75	16.25	20	1.50	Specified by purchaser	14.00	17.00	2.75	6.50	280
16	27.00	23.75	18.50	20	1.63	Specified by purchaser	16.00	19.50	3.00	7.00	390
18	29.25	25.75	21.00	20	1.75	Specified by purchaser	18.00	21.50	3.25	7.25	475
20	32.00	28.50	23.00	24	1.75	Specified by purchaser	20.00	24.00	3.50	7.50	590
22	34.25	30.62	25.25	24	1.88	Specified by purchaser	22.00	26.25	3.75	7.75	720
24	37.00	33.00	27.25	24	2.00	Specified by purchaser	24.00	28.25	4.00	8.00	830

(a) All dimensions are in inches

(b) These flanges will be furnished with a 1/4" raised face unless otherwise specified.