

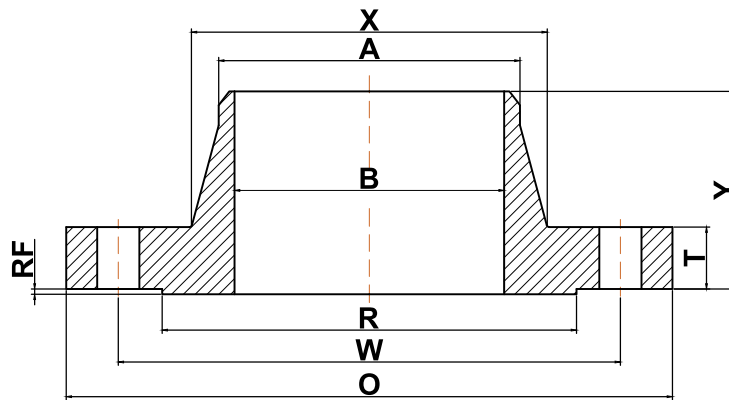

ANSI b16.5

▶ Class 2500 Welding Neck Flanges



Nominal Pipe Size	Outside Diameter (O)	Bolt Circle (W)	Raised Face Diameter (R)	Number of Holes	Diameter of Holes	Bore (B)	Point of Weld (A)	Hub Diameter (X)	Thickness (T)	Length Thru Hub (Y)	Approximate Weight (lbs)
1/2	5.25	3.50	1.38	4	0.88	Specified by purchaser	0.84	1.69	1.19	2.88	7
3/4	5.50	3.75	1.69	4	0.88	Specified by purchaser	1.05	2.00	1.25	3.12	8
1	6.25	4.25	2.00	4	1.00	Specified by purchaser	1.32	2.25	1.38	3.50	12
1 1/4	7.25	5.12	2.50	4	1.13	Specified by purchaser	1.66	2.88	1.50	3.75	17
1 1/2	8.00	5.75	2.88	4	1.25	Specified by purchaser	1.90	3.12	1.75	4.38	25
2	9.25	6.75	3.62	8	1.13	Specified by purchaser	2.38	3.75	2.00	5.00	42
2 1/2	10.50	7.75	4.12	8	1.25	Specified by purchaser	2.88	4.50	2.25	5.62	52
3	12.00	9.00	5.00	8	1.38	Specified by purchaser	3.50	5.25	2.62	6.62	94
4	14.00	10.75	6.19	8	1.63	Specified by purchaser	4.50	6.50	3.00	7.50	145
5	16.50	12.75	7.31	8	1.88	Specified by purchaser	5.56	8.00	3.62	9.00	245
6	19.00	14.50	8.50	8	2.13	Specified by purchaser	6.63	9.25	4.25	10.75	380
8	21.75	17.25	10.62	12	2.13	Specified by purchaser	8.63	12.00	5.00	12.50	580
10	26.50	21.25	12.75	12	2.63	Specified by purchaser	10.75	14.75	6.50	16.50	1075
12	30.00	24.38	15.00	12	2.88	Specified by purchaser	12.75	17.38	7.25	18.25	1525

(a) All dimensions are in inches

(b) These flanges will be furnished with a 1/4" raised face unless otherwise specified.