

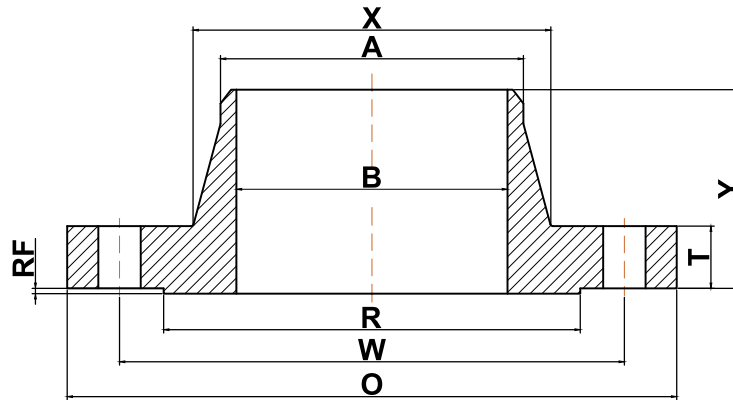

## ANSI b16.5

### ▶ Class 1500 Welding Neck Flanges



Nominal Pipe Size	Outside Diameter (O)	Bolt Circle (W)	Raised Face Diameter (R)	Number of Holes	Diameter of Holes	Bore (B)	Point of Weld (A)	Hub Diameter (X)	Thickness (T)	Length Thru Hub (Y)	Approximate Weight (lbs)
1/2	4.75	3.25	1.38	4	0.88	Specified by purchaser	0.84	1.50	0.88	2.38	5
3/4	5.12	3.50	1.69	4	0.88	Specified by purchaser	1.05	1.75	1.00	2.75	6
1	5.88	4.00	2.00	4	1.00	Specified by purchaser	1.32	2.06	1.12	2.88	9
1 1/4	6.25	4.38	2.50	4	1.00	Specified by purchaser	1.66	2.50	1.12	2.88	10
1 1/2	7.00	4.88	2.88	4	1.13	Specified by purchaser	1.90	2.75	1.25	3.25	13
2	8.50	6.50	3.62	8	1.00	Specified by purchaser	2.38	4.12	1.50	4.00	25
2 1/2	9.62	7.50	4.12	8	1.13	Specified by purchaser	2.88	4.88	1.62	4.12	36
3	10.50	8.00	5.00	8	1.25	Specified by purchaser	3.50	5.25	1.88	4.62	48
4	12.25	9.50	6.19	8	1.38	Specified by purchaser	4.50	6.38	2.12	4.88	73
5	14.75	11.50	7.31	8	1.63	Specified by purchaser	5.56	7.75	2.88	6.12	130
6	15.50	12.50	8.50	12	1.50	Specified by purchaser	6.63	9.00	3.25	6.75	165
8	19.00	15.50	10.62	12	1.75	Specified by purchaser	8.63	11.50	3.62	8.38	275
10	23.00	19.00	12.75	12	2.00	Specified by purchaser	10.75	14.50	4.25	10.00	455
12	26.50	22.50	15.00	16	2.13	Specified by purchaser	12.75	17.75	4.88	11.12	690
14	29.50	25.00	16.25	16	2.38	Specified by purchaser	14.00	19.50	5.25	11.75	940
16	32.50	27.75	18.50	16	2.63	Specified by purchaser	16.00	21.75	5.75	12.25	1250
18	36.00	30.50	21.00	16	2.88	Specified by purchaser	18.00	23.50	6.38	12.88	1625
20	38.75	32.75	23.00	16	3.13	Specified by purchaser	20.00	25.25	7.00	14.00	2050
24	46.00	39.00	27.25	16	3.63	Specified by purchaser	24.00	30.00	8.00	16.00	3325

(a) All dimensions are in inches

(b) These flanges will be furnished with a 1/4" raised face unless otherwise specified.