

➔ ASME B16.47 series A flange

▶ Class 600 Welding Neck Flanges

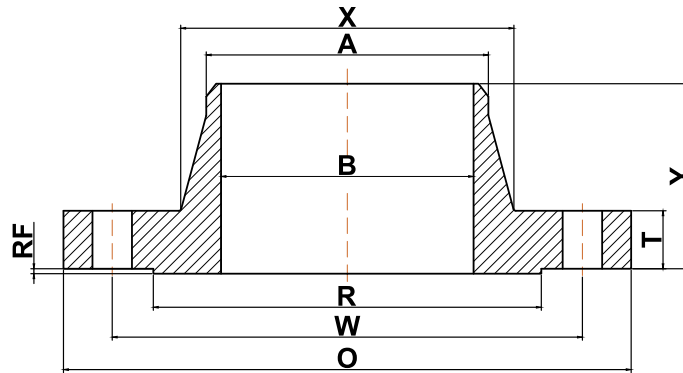

Nominal Pipe Size	Outside Diameter (O)	Bolt Circle (W)	Raised Face Diameter (R)	Number of Holes	Diameter of Holes	Bore (B)	Top of Hub (A)	Hub Diameter (X)	Minimum Fillet Radius (r)	Minimum Thickness (T)	Length Thru Hub (Y)	Approximate Weight (lbs)
26	40.00	36.00	29.50	28	2.00	Specified by purchaser	26.00	29.44	0.50	4.25	8.75	940
28	42.25	38.00	31.50	28	2.12	Specified by purchaser	28.00	31.62	0.50	4.38	9.25	1060
30	44.50	40.25	33.75	28	2.12	Specified by purchaser	30.00	33.94	0.50	4.50	9.75	1210
32	47.00	42.50	36.00	28	2.38	Specified by purchaser	32.00	36.12	0.50	4.62	10.25	1375
34	49.00	44.50	38.00	28	2.38	Specified by purchaser	34.00	38.31	0.56	4.75	10.62	1540
36	51.75	47.00	40.25	28	2.62	Specified by purchaser	36.00	40.62	0.56	4.88	11.12	1705
38	50.00	45.75	41.50	28	2.38	Specified by purchaser	38.00	40.25	0.56	6.00	10.00	1470
40	52.00	47.75	43.75	32	2.38	Specified by purchaser	40.00	42.25	0.56	6.25	10.38	1630
42	55.25	50.50	46.00	28	2.62	Specified by purchaser	42.00	44.38	0.56	6.62	11.00	2030
44	57.25	52.50	48.25	32	2.62	Specified by purchaser	44.00	46.50	0.56	6.81	11.38	2160
46	59.50	54.75	50.25	32	2.62	Specified by purchaser	46.00	48.62	0.56	7.06	11.81	2410
48	62.75	57.50	52.50	32	2.88	Specified by purchaser	48.00	50.75	0.56	7.44	12.44	2855
50	65.75	60.00	54.50	28	3.12	Specified by purchaser	50.00	52.88	0.56	7.75	12.94	3330
52	67.75	62.00	56.50	32	3.12	Specified by purchaser	52.00	54.88	0.56	8.00	13.25	3560
54	70.00	64.25	58.75	32	3.12	Specified by purchaser	54.00	57.00	0.56	8.25	13.75	3920
56	73.00	66.75	60.75	32	3.38	Specified by purchaser	56.00	59.12	0.62	8.56	14.25	4280
58	75.00	68.75	63.00	32	3.38	Specified by purchaser	58.00	61.12	0.62	8.75	14.56	4640
60	78.50	71.75	65.25	28	3.62	Specified by purchaser	60.00	63.38	0.69	9.19	15.31	5000

(a) All dimensions are in inches

(b) These flanges will be furnished with a 1/4" raised face unless otherwise specified.