

## ANSI B16.47 series B flange

### ▶ Class 150 Blind Flanges

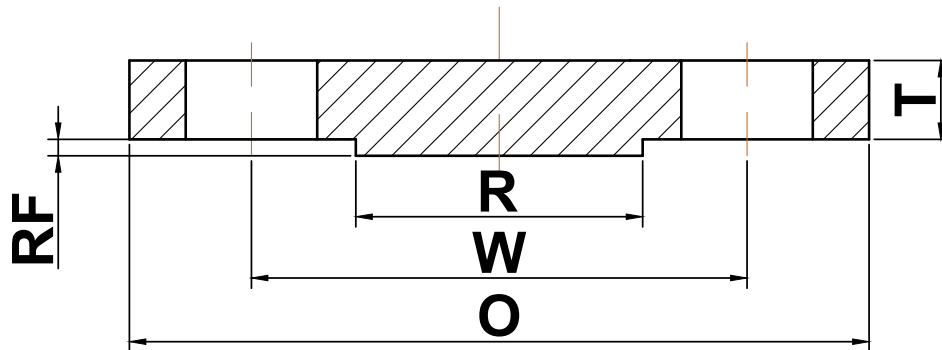

Nominal Pipe Size	Outside Diameter (O)	Bolt Circle (W)	Raised Face Diameter (R)	Number of Holes	Diameter of Holes	Maximum Thickness (T)	Approximate Weight (lbs)
26	30.94	29.31	28.00	36	0.88	1.75	375
28	32.94	31.31	30.00	40	0.88	1.88	455
30	34.94	33.31	32.00	44	0.88	2.00	545
32	37.06	35.44	34.00	48	0.88	2.12	648
34	39.56	37.69	36.25	40	1.00	2.25	782
36	41.62	39.75	38.25	44	1.00	2.31	890
38	44.25	42.12	40.25	40	1.12	2.50	1090
40	46.25	44.12	42.50	44	1.12	2.62	1247
42	48.25	46.12	44.50	48	1.12	2.69	1393
44	50.25	48.12	46.50	52	1.12	2.81	1579
46	52.81	50.56	48.62	40	1.25	2.94	1825
48	54.81	52.56	50.75	44	1.25	3.06	2045
50	56.81	54.56	52.75	48	1.25	3.18	2284
52	58.81	56.56	54.75	52	1.25	3.31	2547
54	61.00	58.75	56.75	56	1.25	3.44	2848
56	63.00	60.75	58.75	60	1.25	3.56	3145
58	65.94	63.44	60.75	48	1.38	3.68	3560
60	67.94	65.44	63.00	52	1.38	3.81	3913

(a) All dimensions are in inches

(b) These flanges will be furnished with a 1/16" raised face unless otherwise specified.